

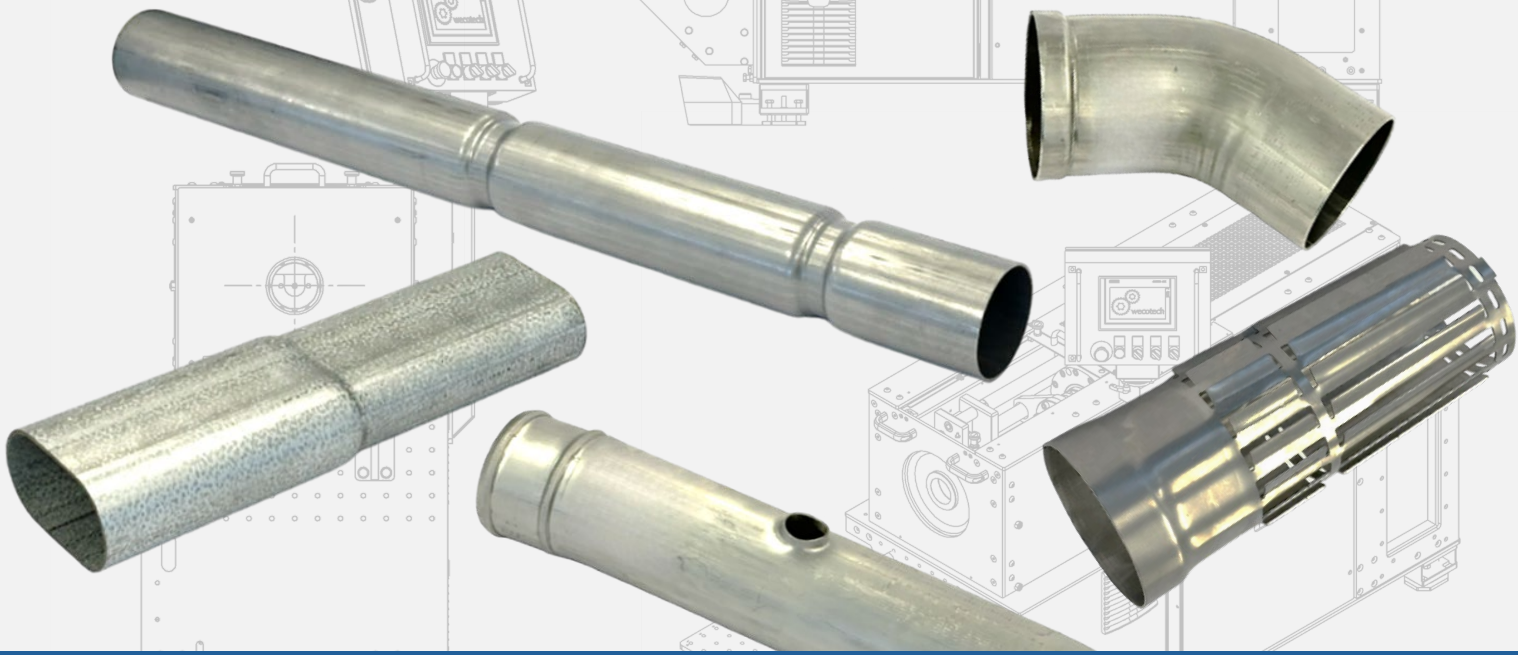

Tube End Forming Machines

IO-type

machines developed for precise **IO-forming and sizing** of oval and round tubes



www.wecotech.ch

+41 71 932 70 40

info@wecotech.ch

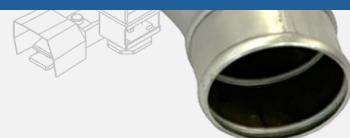

Tubimatic IO 80

diameter range from Ø20 mm up to Ø80 mm

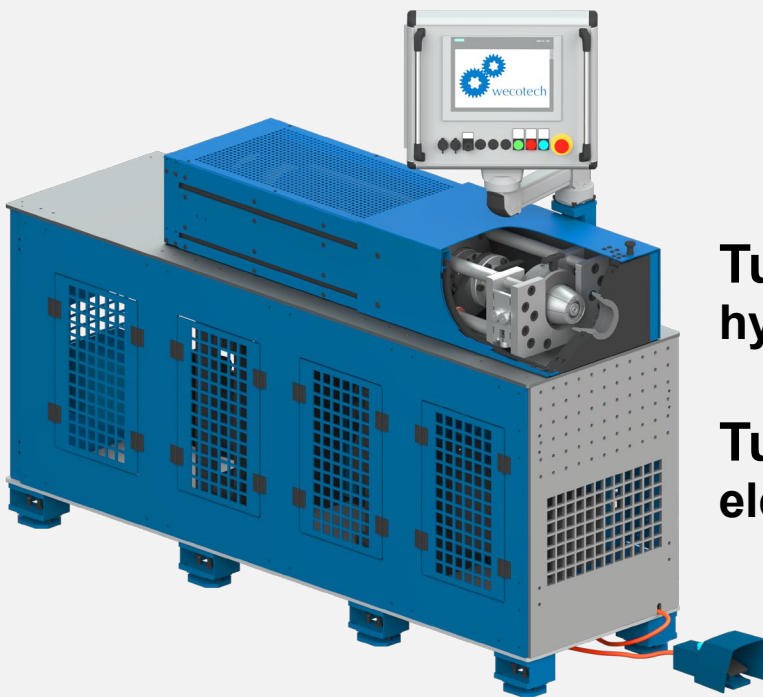

Tubimatic IO 80
hydraulic driven forming axis

Tubimatic IO 80 Electra
electric driven forming axis

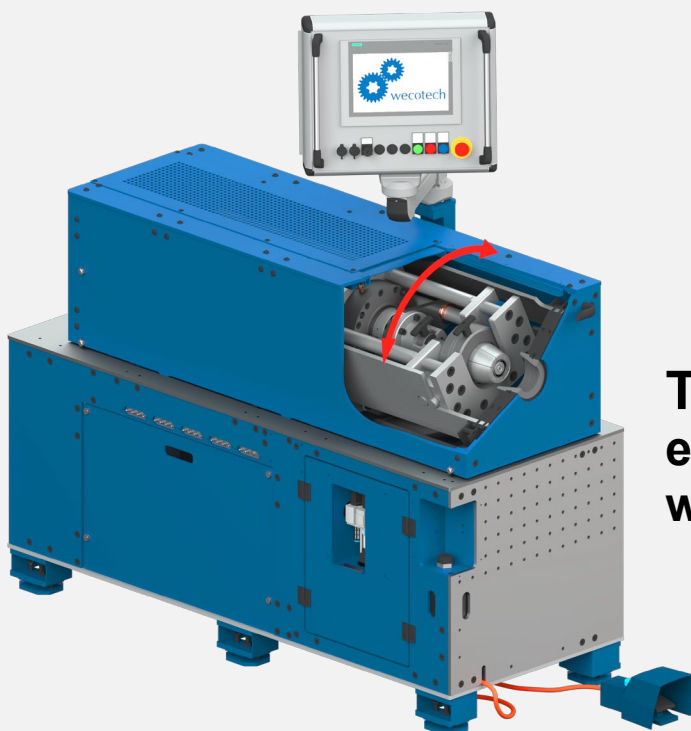

Tubimatic IO-US 80 Electra
electric driven forming axis
with turning function

check the video



Tubimatic IO 160

diameter range from Ø20 mm up to Ø160 mm

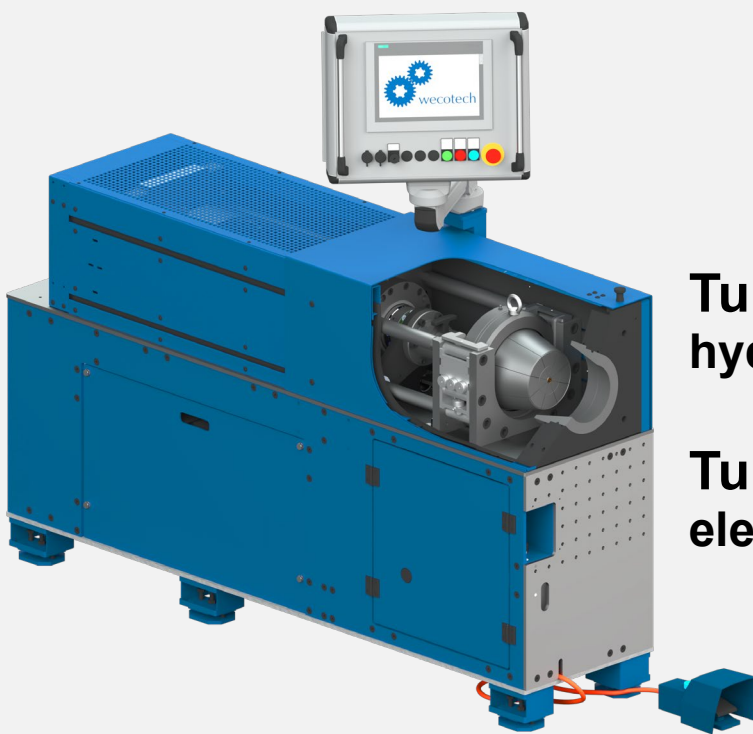

Tubimatic IO 160
hydraulic driven forming axis

Tubimatic IO 160 Electra
electric driven forming axis

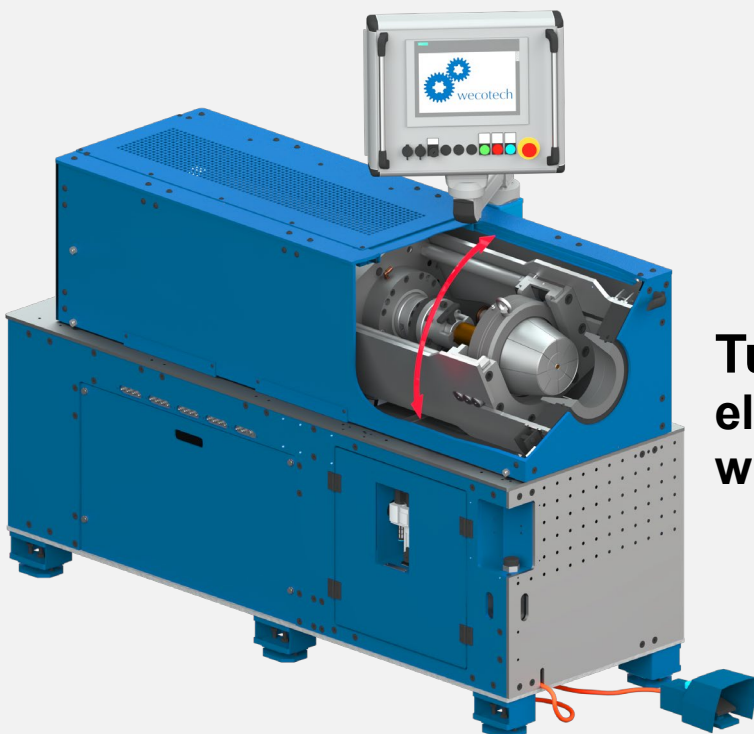

Tubimatic IO-US 160 Electra
electric driven forming axis
with turning function

check the video



Tubimatic IO options

supporting table for positioning fixtures

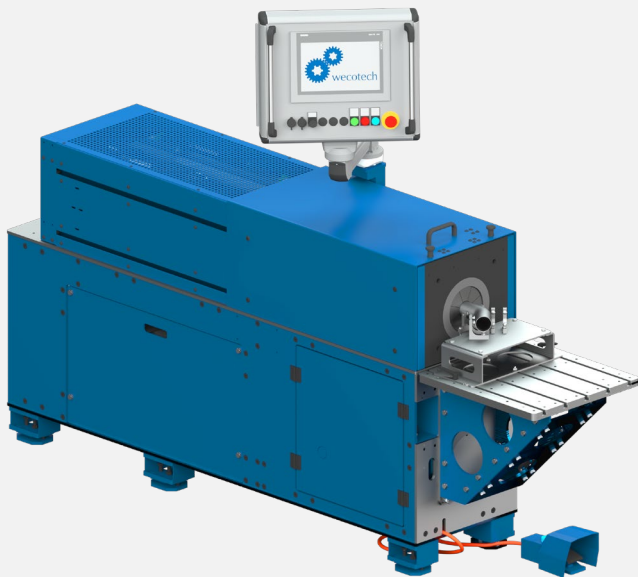

Supporting table with guiding grooves for easy loading and precise positioning of tubes, ensuring stable handling and accurate alignment during operation.

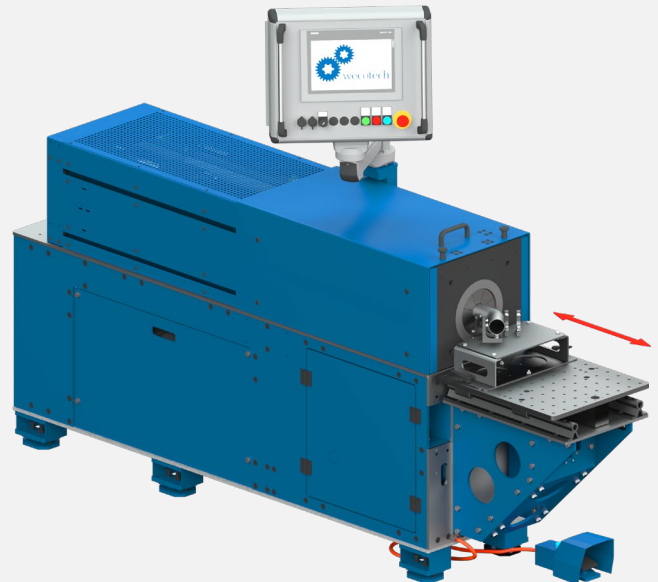

Insertion slide device (servo-electric driven) with forward and backward movement and automatic clamping device for secure tube positioning and perfect alignment during forming operations.

pressing head

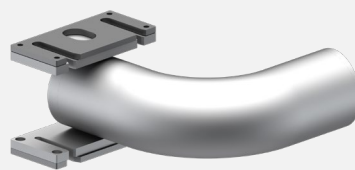
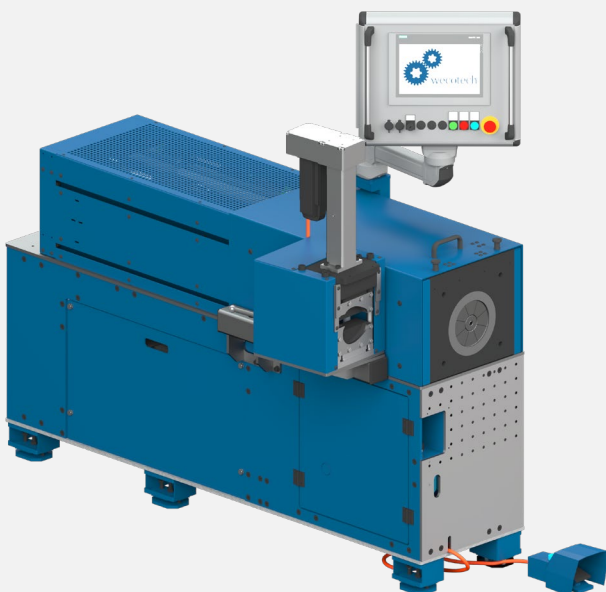

Designed for sizing tubes after bending operations. The pressing process is applied to achieve optimal calibration results, ensuring precise and consistent tube geometries.

double head machine

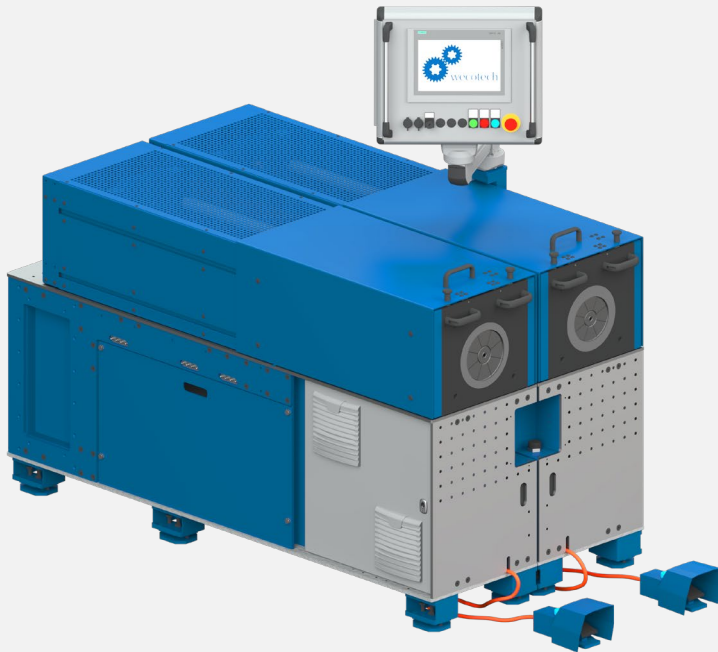

The double head machine combines two forming heads in a single machine, enabling sequential operations without tool changes. It allows different forming operations in the same machine, increasing flexibility and efficiency for complex tube processing.

safety guard with light curtain

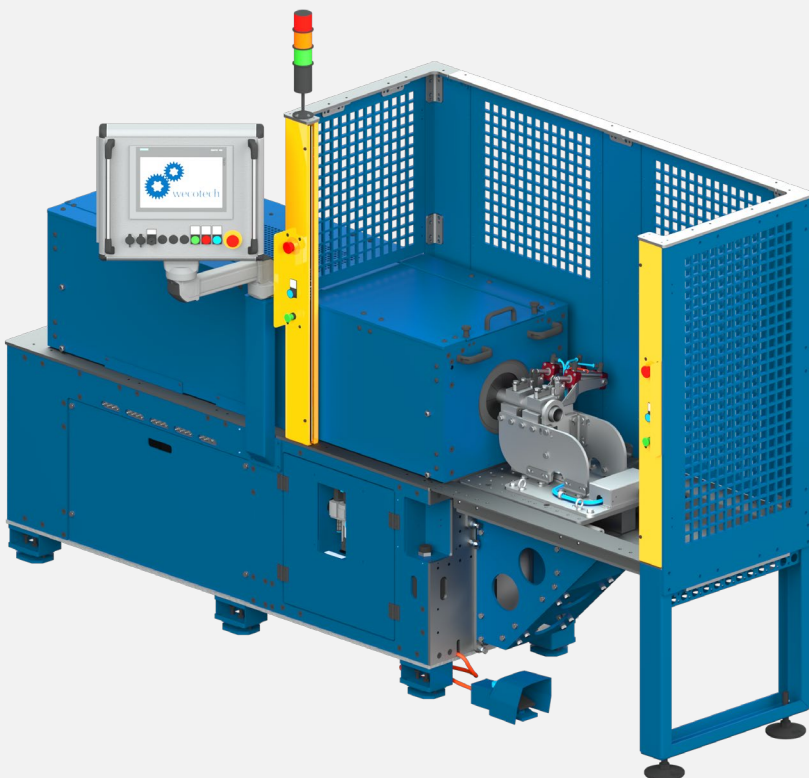

The grid fence with safety light curtain ensures operator protection and prevents access to hazardous areas during the forming process.

This solution improves workplace safety while ensuring efficient production processes.

forming depth extension

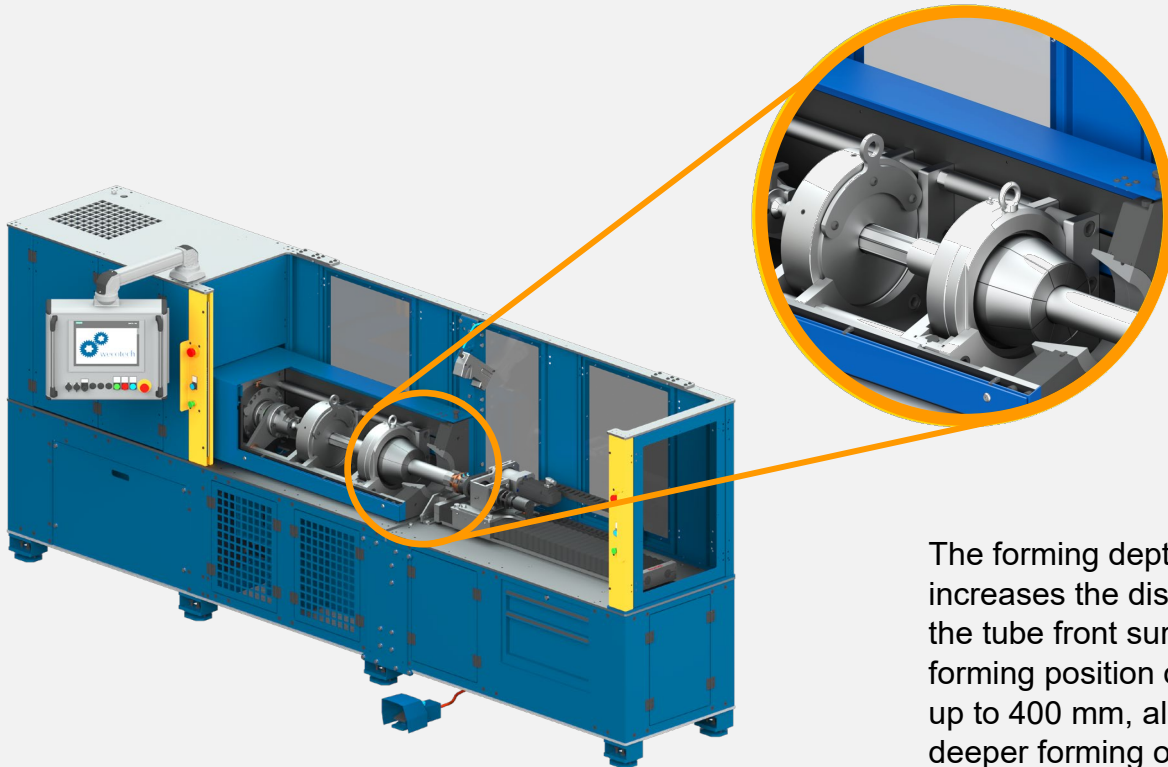

The forming depth extension increases the distance from the tube front surface to the forming position of the tube up to 400 mm, allowing deeper forming operations.

robot interface

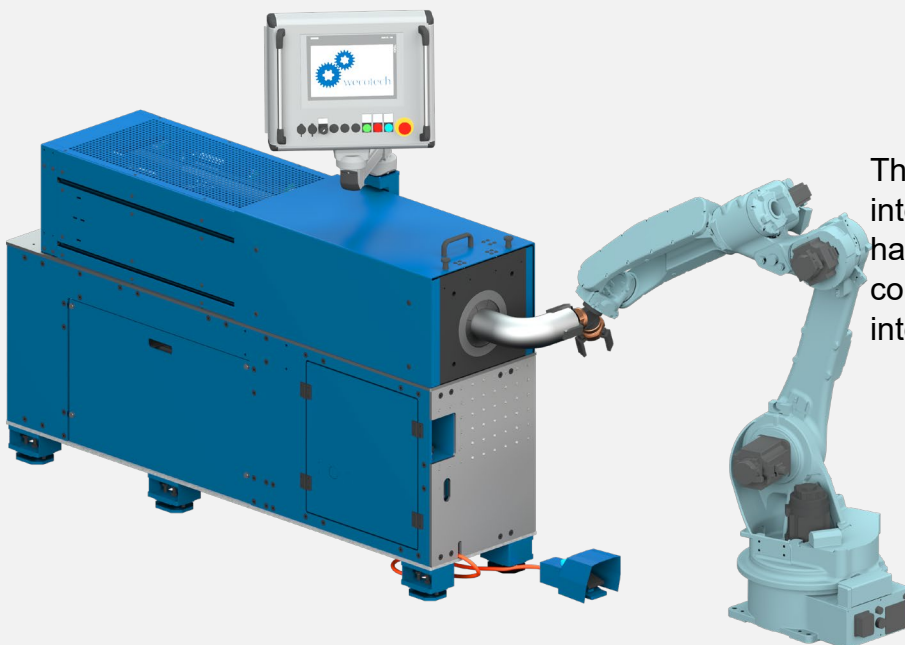

The machine is equipped with an interface for use with robots or handling systems. The pre-configured interface allows smooth integration into production cells.

IO-machine concept

IO forming

During the forming process, the tube needs to be rotated by hand, a handling system or a robot.

IO-US forming

The rotation of the forming head, combined with the fixation of the tube, enables an automatic forming process independent of the operator.

performance benefits

The forming cycle is freely programmable, enabling maximum flexibility and precision for a high range of applications.

Our tools are compatible with standard IO machines. Based on a well-engineered design and customized manufacturing, highest requirements can be met with respect to a concentric forming with defined shape and transitions.

The standard tools are on stock at Wecotech.



IO-forming

standard IO-forming
solution for straight sizing operation

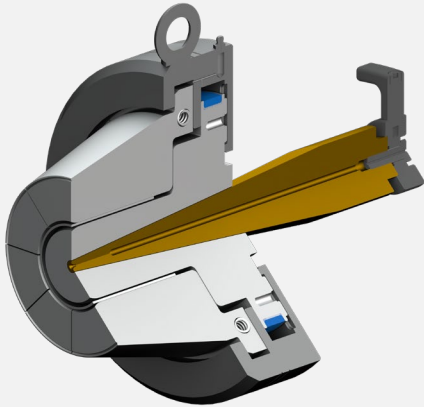

IO radial reducing and expanding
solution for reducing or expanding concentric to tube axis with defined transition

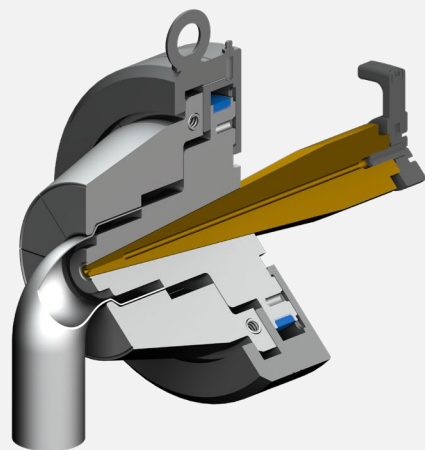
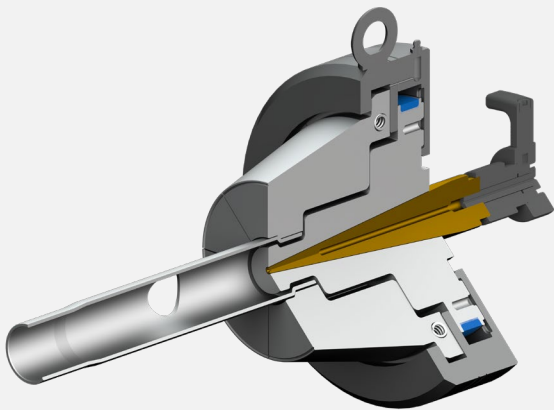

IO-shaping
solution to form a customized shape

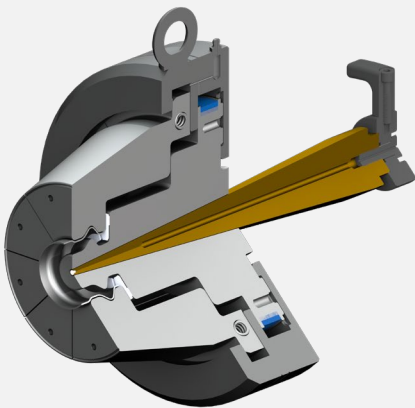

composed of:

- cone
- inner and outer tool
- housing

IO-specials

limitless shapes

Most complex shapes can be realized reliably and cost-effectively, powered by many years of experience and high technical expertise. Tube end forming is not limited to round geometries; Wecotech solutions offers the precise forming of oval, square and conical shapes possible. In addition, our advanced forming capabilities allows for non-circumferential tube geometries, even in demanding and challenging component designs.

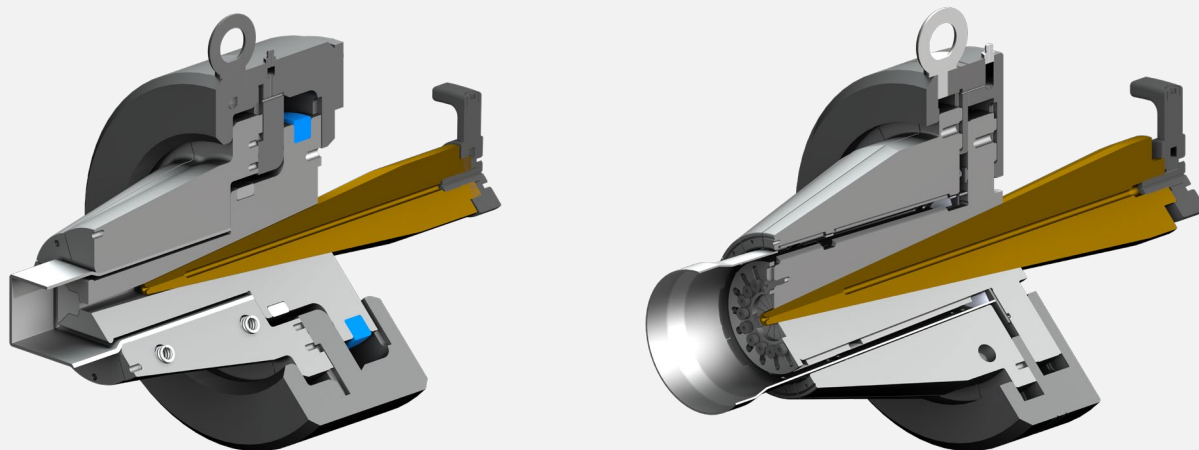

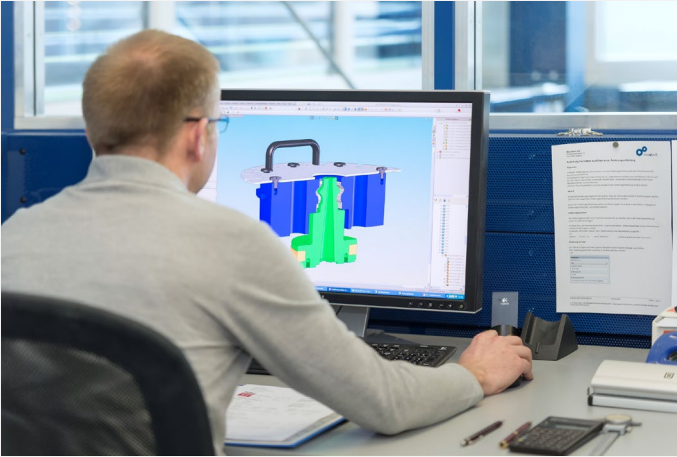

Wecotech AG is your partner in the field of tube end forming.

With technical **expertise**, **experience** and **passion**, we develop solutions where standard concepts reach their limits.

Our goal is to face and solve the toughest challenges.

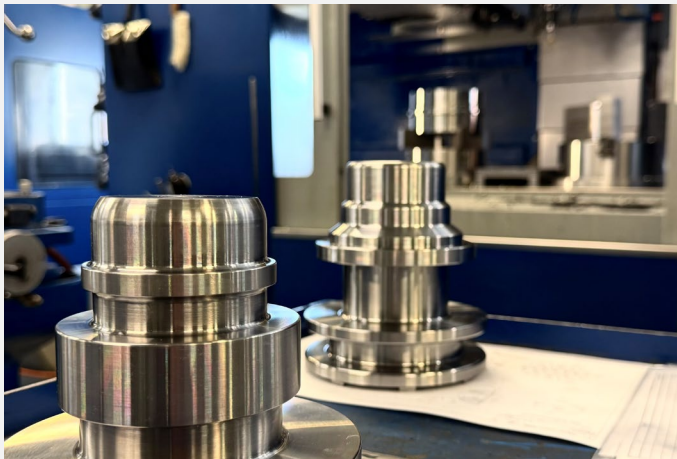

We design and manufacture our tools and machines entirely in-house **precisely, individually**, and **perfectly customized** to your requirements.

From engineering to production, every step is handled in-house ensuring highest quality and maximum process reliability.



Our tools are tested under production conditions and precisely fine-tuned. Through optimisations and exact process alignment, we ensure that your tube is formed within the specified tolerances, delivering stable processes and reliable series production quality.



technical data

	Tubimatic IO	Tubimatic IO Electra	Tubimatic IO-US Electra
PRODUCT RANGE (IO 80)			
diameter	Ø20-80 mm	Ø20-80 mm	Ø20-80 mm
forming length	up to 100 mm	up to 100 mm	up to 100 mm
wall thickness	up to 3 mm	up to 3 mm	up to 3 mm
range of forming length, diameter and wall thickness can vary product specific			
PRODUCT RANGE (IO 160)			
diameter	Ø20-160 mm	Ø20-160 mm	Ø20-160 mm
forming length	up to 180 mm	up to 180 mm	up to 180 mm
wall thickness	up to 3 mm	up to 3 mm	up to 3 mm
range of forming length, diameter and wall thickness can vary product specific			
HYDRAULIC UNIT			
tank volume	100 l	N/A	N/A
flow rate	25 l/min	N/A	N/A
pressure	300 bar	N/A	N/A
motor	11 kW	N/A	N/A
ELECTRIC UNIT			
connection 400V / 50Hz / 3L + PE	32 A	32 A	32 A
PLC Siemens (fail safe)	✓	✓	✓
touchscreen 12"	✓	✓	✓
forming program settings	CNC-programming	CNC-programming	CNC-programming
MACHINE FEATURES			
axis movement	hydraulic	servo-electric	servo-electric
turning unit for forming head	N/A	N/A	✓
working position	horizontal	horizontal	horizontal
dimension Tubimatic IO 80	1600x800x1700 mm	2000x600x1700 mm	2000x700x1750 mm
dimension Tubimatic IO 160	1900x800x1700 mm	2000x500x1700 mm	2000x700x1850 mm

Tube-End-Forming For World's Leading Industries

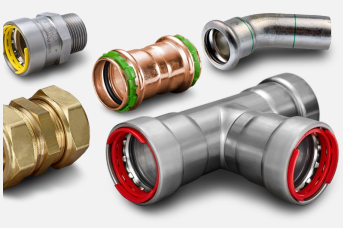



Wecotech AG

Silberwisstrasse 14
9534 Gaehwil
Switzerland

Your trust inspires us to develop and provide solutions that meets the highest requirements.

At Wecotech, we are more than a company – a partner which focus on forming your ideas.

Together we realize challenges efficiently by simplicity and clarity, the customer benefit in sight.

Your goals guide our work, and your success measures ours.

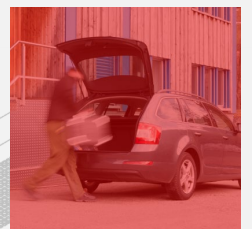
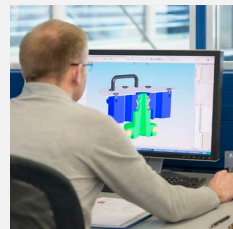
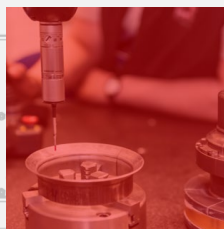
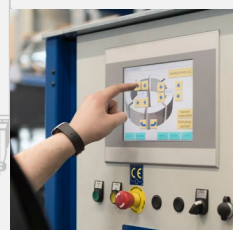
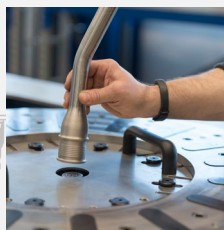
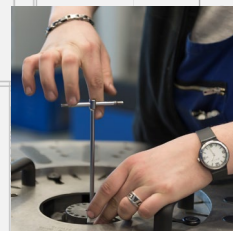
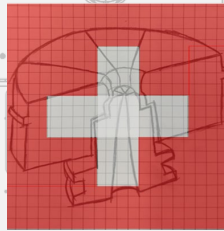

www.wecotech.ch

+41 71 932 70 40

info@wecotech.ch